

## High performance emergency high/low bay luminaires

Non-maintained emergency high/low bay luminaire with high lumen output to illuminate open areas, escape routes or points of emphasis. Minimal dust collection body profile and optional narrow or broad optics to distribute light in the required direction. Snap-fit stainless steel mounting brackets for easy installation.

Applications: industrial, warehouse, logistics centres, large open areas, sports halls.

- High quality control gear and LEDs designed to achieve 100,000 hour life expectancy
- Broad or narrow distribution
- Smooth wipe clean surfaces, no dust traps
- Three hour, non-maintained operation
- Complies with food production standards IFS, HACCP and BRC
- SmartScan wireless technology removes the need for control cabling. Ideal for retro-fit



IP64

IK11

SMARTSCAN

### Specification

Mounting	Surface	IP rating	IP64
Impact rating	IK11		

### Emergency data

Emergency lumen output	1,095 lm - 1,150 lm	Emergency type	Non-maintained
Emergency duration	3 hours	Battery specification	Nickel Metal Hydride (NiMH)

### Power

LED power	8 W
-----------	-----

### LED characteristics

Colour temperature	4000 K
--------------------	--------

## Compliance

UKCA	Yes	CE	Yes
D Mark	Yes	Ball impact resistance	DIN EN 18032 Part 3 and DIN VDE 0710 Part 13

## Dimensions

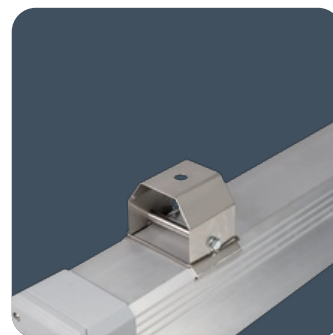
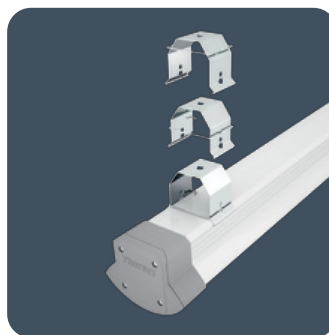
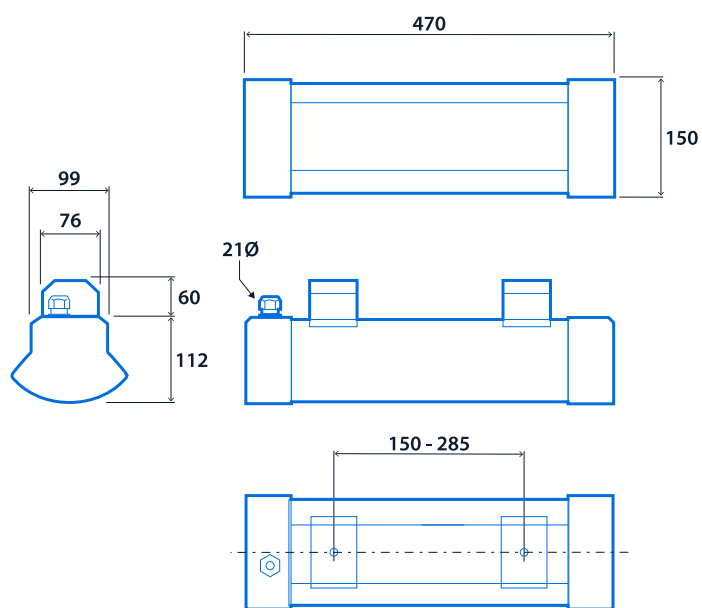



**Click or scan here**  
View Solow LED Emergency  
variants using our online  
filtering tool



Information is correct as of 15-Jan-2025, however must not be interpreted as a guarantee of individual product performance and/or characteristics. We reserve the right to alter specifications and designs without prior notice.