

Recessed picture luminaire with dual light engine

Flexview is a recessed lay-in luminaire with a dual light engine combining low power edge-lit technology for its picture window with a separate sophisticated, highly efficient low glare optics for main space illumination. Flexview allows creativity, enhancing the look and feel of a space whilst still providing quality functional lighting.

Applications: Teaching spaces, Offices, Corridors, Waiting rooms, Break-out spaces, Reception areas, Retail, Windowless rooms.

- Dual light engine design, perimeter light engine for main illumination and secondary light engine for the picture window
- Black 'invisible' light source, metallised low glare and white reflector options
- Wattage selectable during installation
- Edge-lit panel remains at constant brightness (does not dim)
- Image screen printed onto 1.5 mm polycarbonate TP(a) rated fire-retardant panel
- Multiple kit options available, all with the primary light engine only around the perimeter of the array



IP20

Up to 105.7 LL/CW

Lighting management

Lighting control system	Dimming (DALI) Non-dimming SmartScan Internal	Emergency system	AutoTest Emergency Non-emergency SmartScan Emergency Standard Emergency
-------------------------	---	------------------	--

Specification

Mounting	Recessed	IP rating	IP20
Max presence detection height	8 m		

Lighting

Lumen output	1,630 lm - 11,025 lm	Efficacy	Up to 105.7 LL/CW
--------------	----------------------	----------	-------------------

Emergency data

Emergency lumen output	259 lm - 370 lm	Emergency type	Maintained
Emergency duration	3 hours	Battery specification	Nickel Metal Hydride (NiMH)

Power

LED power	20 W - 148 W	Circuit power	24 W - 164 W
-----------	--------------	---------------	--------------

Construction

Thermoplastic rating TP(a)

LED characteristics

CRI 80+ Colour temperature 4000 K
 Rated life (hours) 100 K - L80/B10

Compliance

UKCA	Yes	CE	Yes
Energy efficiency class	This product contains a light source of energy efficiency class B	SmartScan wireless standards compliance	Europe: EN 300 220-1 V2.4.1/ EN 301 489-3 V1.6.1. Australasia: ACMA 2014 Radio Communication Standard 2014. Thorlux Patented Wireless Technology - GB2575724

Dimensions

Per Flexview module

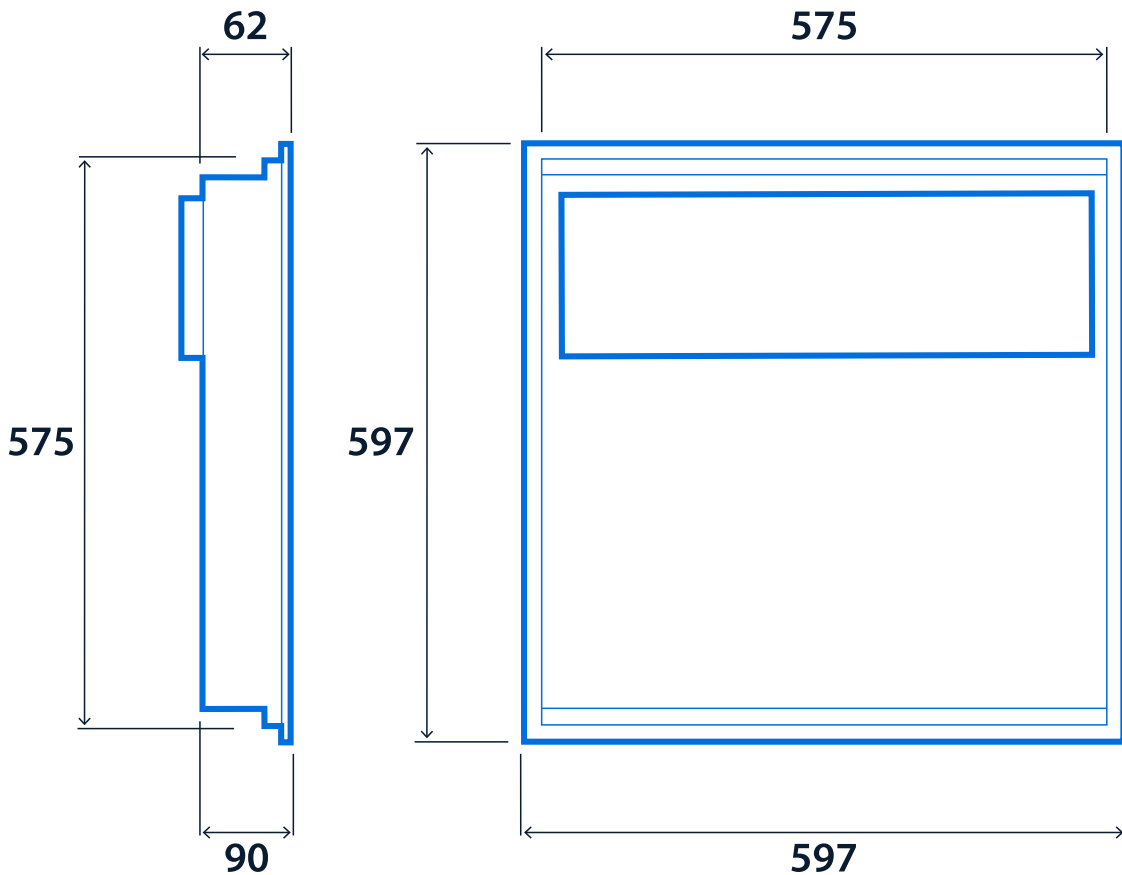

NOTE: Suitable for exposed T-Bar lay-in ceilings only



View the





range

