

## Cleanroom LED recessed luminaires

IP65 recessed modular luminaires with quick release extruded aluminium cover frame and a choice of two front covers. Satisfies the requirements of cleanroom classifications FS209D 10,000 and 100,000 and ISO BSEN 14644-1, 7 and 8.

Applications: printing works, water treatment plants and pump rooms, industrial process areas, shower rooms and toilet blocks, food preparation areas.

- Quick release extruded aluminium cover frame
- Cover seals to ceiling with FDA approved silicone gasket
- Optional tamper-resistant cover screws
- Fits most suspended ceiling types or cut apertures
- SmartScan wireless technology removes the need for control cabling. Ideal for retro-fit

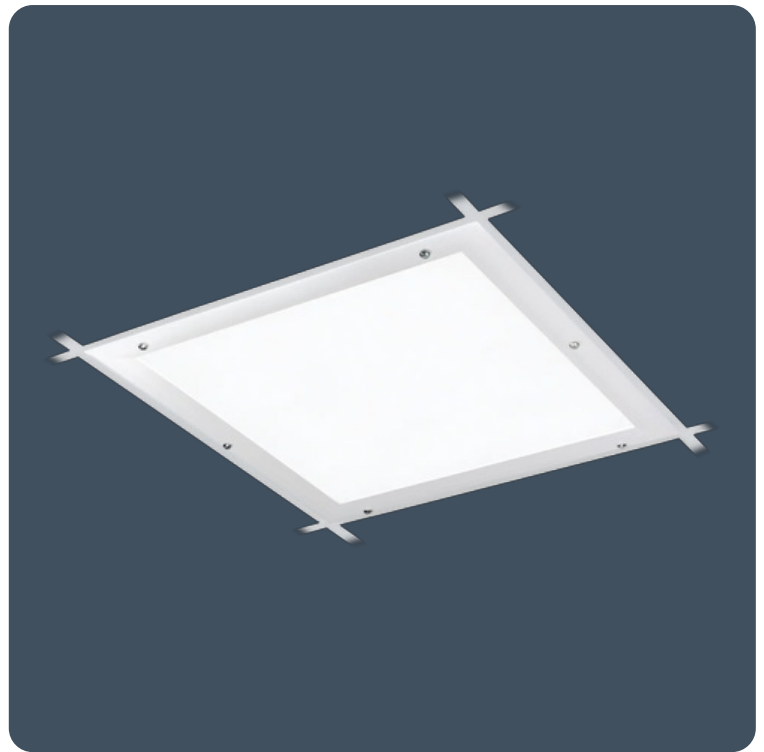

IP65 (IP20 above ceiling)

IK10

Up to 116.3 LL/CW

SMARTSCAN

LUXGUARD

### Specification

Mounting	Recessed	IP rating	IP65 (IP20 above ceiling)
Impact rating	IK10	Max presence detection height	8 m

### Lighting

Optic	Low glare diffuser Opal diffuser	Lumen output	2,250 lm - 4,805 lm
Efficacy	Up to 116.3 LL/CW		

### Emergency data

Emergency lumen output	215 lm - 300 lm	Emergency type	Maintained
Emergency duration	3 hours	Battery specification	Nickel Metal Hydride (NiMH)

### Power

LED power	26 W - 38 W	Circuit power	30 W - 43 W
-----------	-------------	---------------	-------------

### LED characteristics

CRI	80+ 90+	Colour temperature	4000 K
Rated life (hours)	100 K - L80/B10		

## Dimensions

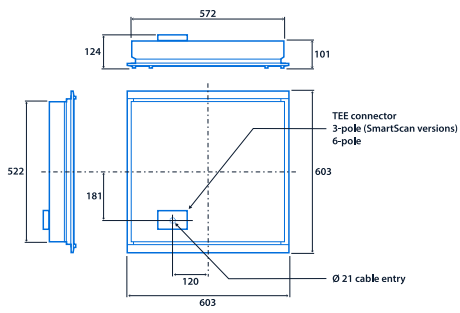

View the  
range



Information is correct as of 03-Dec-2024, however must not be interpreted as a guarantee of individual product performance and/or characteristics. We reserve the right to alter specifications and designs without prior notice.