

High performance wall mounted EV chargers

The Azmet EV is a compact workplace EV charging solution, embodying simplicity and robust functionality. Crafted with a durable housing, it ensures impact resistance, UV protection, and flame retardancy for reliable, long-term use.

Designed to empower users with complete control over their charging experience, the Azmet EV offers a powerful, OCPP 1.6-compliant solution in a streamlined design. Its quick installation process, integrated cable storage hub, and LED charging indicator offer both convenience and clarity. A fully protected, maintainable and serviceable EV charger that benefits from over the air updates.

The Azmet EV easily connects to the cloud via Wi-Fi, ethernet, or 4G, with full control available through the free mobile app.

- Single and three phase options
- Socketed or 5 m tethered cable options
- Fast commissioning access control and security via mobile app
- Option of PV integration and dynamic load management
- PEN fault on single phased devices
- Power sharing of up to 4 devices on a single mains feed
- Fully compliant with The Electric Vehicles (Smart Charging Points) Regulations 2021
- OCPP enables connection to any 3rd party back office



IP54

Specification

IP rating **IP54**

EV charging

Socket	Single	Charging speed	7.4 kW 22 kW
Power input	Single phase Three phase	Connectivity	4G Ethernet port Wi-Fi

Compliance

UKCA **Yes** CE **Yes**

Dimensions

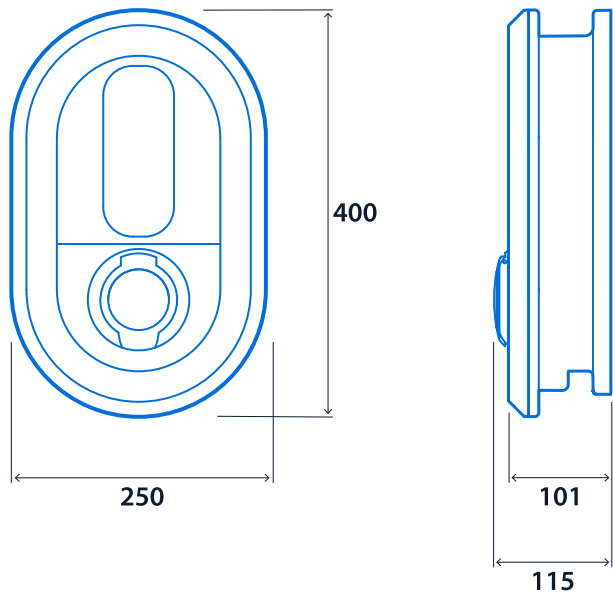

Click or scan here
View Azmet EV variants using
our online filtering tool



Information is correct as of 22-Jan-2025, however must not be interpreted as a guarantee of individual product performance and/or characteristics. We reserve the right to alter specifications and designs without prior notice.